

# CARBON MONOXIDE ALARM

CAT. **C0400B**



## ELECTROCHEMICAL CO SENSOR

Most accurate technology available for detecting carbon monoxide as compared to other sensing technologies

## TWO SILENCE FEATURES

Silences low battery chirp for up to eight hours or silence nuisance alarm for several minutes.

## END OF LIFE SIGNAL

Provides audible and visual notice when alarm needs to be replaced.

## 9V ALKALINE BATTERY INCLUDED

# First Alert®

## 9V Battery Powered

### Description:

The First Alert Cat. No. C0400B is a alkaline battery operated, 9V single station carbon monoxide alarm specifically designed for residential and institutional applications including sleeping rooms of hospitals, hotels, motels, dormitories and other multi-family dwellings as defined in standard NFPA 720. Model C0400 complies with UL2034, NFPA 720 and other agencies that model their codes after the above agencies.

First Alert C0400B features an electrochemical CO sensor, an 85dB horn, End of Life and silence features, a single button for test/silence and a red LED that blinks to indicate unit is receiving power. The low power warning indicator will cause the alarm to "chirp" when the battery needs replacing. The low power warning indicator can be silenced for up to 8 hours. Includes mounting anchors and screws.



# CAT. C0400B

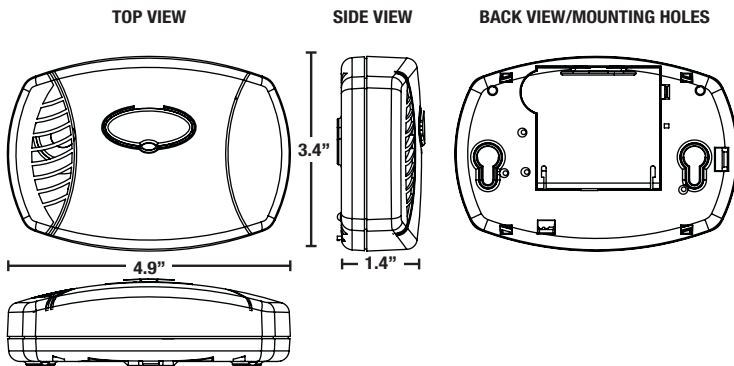

## ARCHITECTURAL AND ENGINEERING SPEC

The carbon monoxide alarm shall be a First Alert Model C0400B and shall provide at a minimum the following features and functions:

1. An electrochemical CO sensor.
2. The unit shall have an "End of Life" signal. This signal should be capable of temporarily being silenced for up to 2 days. After about 2 days, the signal will resume. After about 2-3 weeks the signal cannot be silenced.
3. Powered by a supervised 9V battery and a solid state piezo horn rated at 85dB at 10 ft.
4. A visual LED power-on indicator to confirm unit is receiving power or is in alarm.
5. Two Silence features - Low Battery Silence: Silence low battery chirp for up to 8 hours. Alarm Silence: Temporarily silence unwanted nuisance alarms.
6. A full function test button should check all alarm functions by simulating a CO condition, causing the unit to alarm.
7. The CO sensor is adjusted not to detect CO levels below 30 PPM and will not alarm when exposed to constant levels of 30 PPM for 30 days. It will alarm at the following levels: 400 PPM CO between 4 and 15 minutes, 150 PPM CO between 10 and 50 minutes and 70 PPM CO between 60 and 240 minutes.
8. The unit shall be capable of operating between 40°F (4°C) and 100°F (38°C) and relative humidity between 10% and 95%.
9. The unit shall contain mounting hardware and shall be listed for wall or ceiling mounting.
10. The unit shall at a minimum meet the requirements of UL2034, NFPA 720, NFPA 101, ICC.

## INSTALLATION OF ALARM

Installation of this alarm must conform to NFPA 720. Always check your local building codes. Follow all instructions for placement as outlined in the user's manual.

### THE PARTS OF THIS CO ALARM

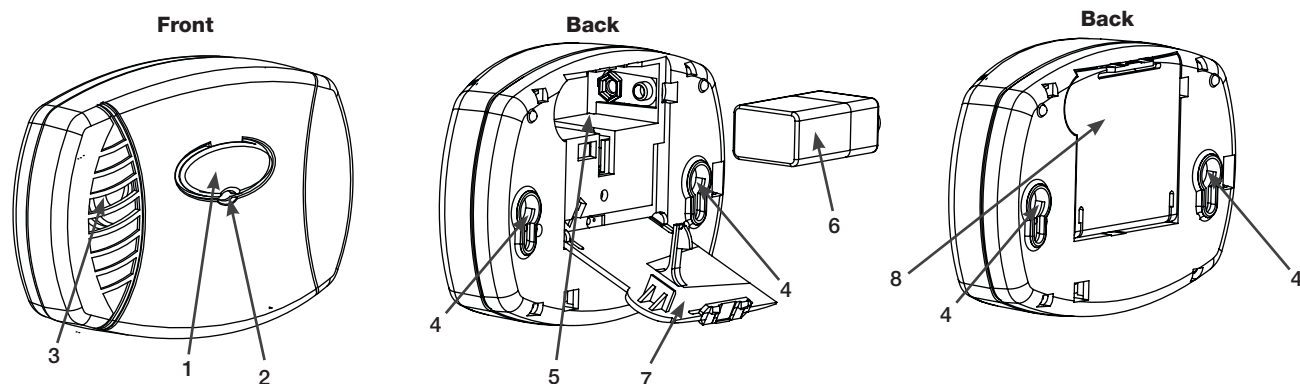

1. Test/Silence button
2. POWER/ALARM Light
3. Horn
4. Standard screw mounting slots
5. Install 9V battery here
6. 9V Battery
7. Battery Drawer
8. Battery Drawer Closed

## TECHNICAL SPECS

|                          |   |
|--------------------------|---|
| Alarm Dimensions:        | 4.9" L x 3.4" H x 1.4" D  |
| Weight:                  | 5.6 oz  |
| Operating Voltage:       | 9V Alkaline Battery Powered   |
| Temperature Range:       | 40°F (4°C) to 100°F (38°C)  |
| Humidity Range:          | 10% to 95% relative humidity (RH)   |
| Audio Alarm:             | 85dB at 10 feet   |
| Test/Silence:            | Electronically simulates CO condition, causing the unit to alarm. Press and hold test/silence button. |
| Alarm Reset:             | Automatic when CO clears  |
| CO Sensor:               | Electrochemical   |
| Indicator Lights/Sounds: |   |
| DC Power:                | Intermittent Red LED  |
| Local Alarm:             | Audio Alarm (4 beeps, pause, 4 beeps), rapidly flashing RED LED                                       |
| Listing:                 | Listed to UL2034 Standard   |

## SHIPPING SPECS

|                              |                             |
|------------------------------|-----------------------------|
| Individual Carton Dimensions | 5.50" L x 3.38" H x 1.83" D |
| Weight                       | 0.45 lbs.                   |
| Cube                         | 0.02 ft <sup>3</sup>        |
| UPC                          | 0 29054 00074 3             |
| Master Carton Dimensions     | 7.25" L x 5.38" W x 6.0" H  |
| Master Pack                  | 6                           |
| Weight                       | 2.9 lbs.                    |
| Cube:                        | 0.14 ft <sup>3</sup>        |
| I2of5:                       | 600 29054 00074 5           |
| Pallet Information           |                             |
| Cases per Layer              | 45                          |
| Number of Layers:            | 6                           |
| Cases per Pallet:            | 270                         |
| Units per Pallet:            | 1,620                       |
| Cube:                        | 49.6 ft <sup>3</sup>        |
| Weight:                      | 844 lbs.                    |



©2013 BRK Brands, Inc. a Jarden Corporation Company (NYSE: JAH)  
3901 Liberty Street Road  
Aurora, IL 60504-8122  
All rights reserved

First Alert is a registered trademark of the First Alert Trust  
BRK is a registered trademark of BRK Brands, Inc.  
CM3175